

Complex Formation of Calcium(II) with Amino Acids under Physiological Conditions

Masunobu Maeda,* Kohji Okada, Yoshihiro Tsukamoto, Kazushiro Wakabayashi, and Kaname Ito
 Department of Applied Chemistry, Nagoya Institute of Technology, Gokiso-cho, Showa-ku, Nagoya 466,
 Japan

The complex formation of calcium(II) with glycine(HL), DL-alanine(HL), β -alanine(HL), and DL-aspartic acid(H₂L) was investigated under physiological conditions (at 37 °C in 0.15 mol dm⁻³ NaCl aqueous solution) by potentiometric titrations using both calcium-ion selective and glass electrodes. The e.m.f. data for the glycine, DL-alanine, and β -alanine systems were explained with only one species [CaL]⁺ and those for the DL-aspartic acid system with two, [Ca(HL)]⁺ and [CaL]. Nitrogen-14 and ¹⁷O n.m.r. spectral measurements suggested that both the amino and carboxylate groups co-ordinate to Ca^{II} within the complexes in the glycine, DL-alanine, and β -alanine systems. N.m.r. spectra could not be obtained for the complexes in the DL-aspartic acid system because of the low solubility of that acid.

A number of investigations have been made on the complex formation between metal ions and ligands related to biological systems.¹⁻³ However, few have been performed under physiological conditions (37 °C and ionic strength = 0.15 mol dm⁻³). Thus, there is a need for further more accurate data on the composition and stability constants of the complexes, determined under those conditions, for biological ligands and biologically essential as well as toxic metal ions.⁴

In the present work the complex formation of calcium(II) with glycine, DL-alanine, β -alanine, and DL-aspartic acid was chosen as the first of a series of studies under physiological conditions (at 37 °C in 0.15 mol dm⁻³ NaCl aqueous solution), since a number of processes in biological systems are specifically dependent upon calcium ions.⁵ Only a few investigations of the present systems, which have been carried out by pH titrations and yet under different conditions from biological ones, seem to have been reported.^{2,6} Based on the available stability constants, it is understood that calcium(II) forms very unstable complexes with those ligands. This fact suggests that it is essential to measure the equilibrium concentrations of not only hydrogen ions, but also calcium ions, so that the composition and stability constants of the complexes, which may be present in small amounts, may be more accurately and precisely determined. Thus, in the present work, the equilibrium concentrations of both hydrogen and calcium ions were measured by means of a glass electrode and a calcium-ion selective electrode, respectively.

Nitrogen-14 and ¹⁷O n.m.r. spectra were measured for the complexes in aqueous solution so that the binding sites of the amino acids could be deduced. Nitrogen-15 n.m.r. spectra could not be obtained due to the low content of natural ¹⁵N.

Experimental

Reagents and Analysis.—Glycine(HL), DL-alanine(HL), β -alanine(HL), and DL-aspartic acid(H₂L) were recrystallised and dried according to the procedures described by Perrin *et al.*⁷ Calcium chloride was also purified according to Perrin *et al.*⁷ Other reagents were prepared and analysed as described in previous papers.^{8,9} The correction of the concentrations of solutions determined at 25 °C to those at 37 °C was made with the densities of the solutions measured at these temperatures.

Apparatus and Procedures for Potentiometric Titrations.—A microcomputer-controlled automatic titration apparatus was

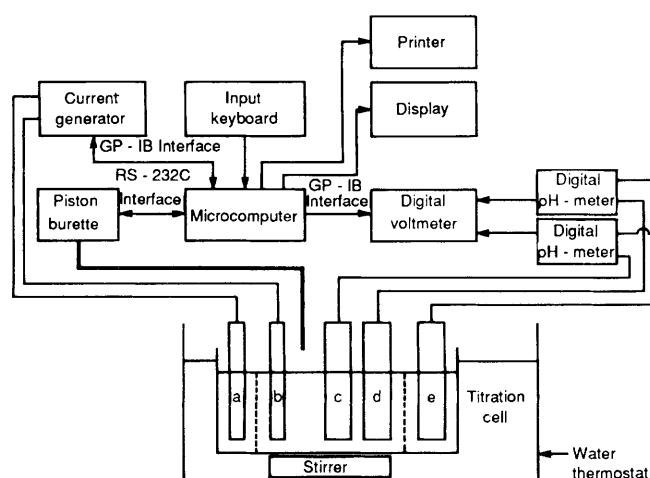

Figure 1. Block diagram for automatic potentiometric measurements aided by a microcomputer: a = silver electrode or platinum electrode; b = platinum electrode; c = calcium-ion selective electrode; d = glass electrode; e = silver-silver chloride reference electrode

assembled for the present measurements. A block diagram is shown in Figure 1. The system consisted of a microcomputer (NEC, PC-9801vm21), a display (NEC, PC-KD854), a printer (NEC, MINIACE NM9900), digital pH-meters (Denki Kagaku Keiki, ion meter model IOC-10), an automatic piston burette (Kyoto Electronics, APB-118), a current generator (Advantest, programmable d.c. voltage/current generator TR6142), and a titration cell immersed in a water thermostat kept at 37.00 ± 0.01 °C. The connection between the computer and the pH-meters were realised by a digital voltmeter (Keithley, 199 System DMM/SCANNER) and a GP-IB standard interface. The burette was linked to the computer by an RS-232C standard interface. The current generator, which is useful for coulometric titrations to generate *in situ* either H⁺ or OH⁻ ions, was connected to the computer by a GP-IB standard interface. The titration cell, in which were set a glass electrode (Beckman no. 39301), a calcium-ion selective electrode (Denki Kagaku Keiki, type 7430), and a silver-silver chloride reference electrode prepared according to Brown,¹⁰ was essentially similar to that designed by Biedermann and co-workers.¹¹

The e.m.f.s for the calcium-ion selective (c.i.s.e.) and glass (g.e.) electrodes were measured for the cell c.i.s.e., g.e. | equilibrium

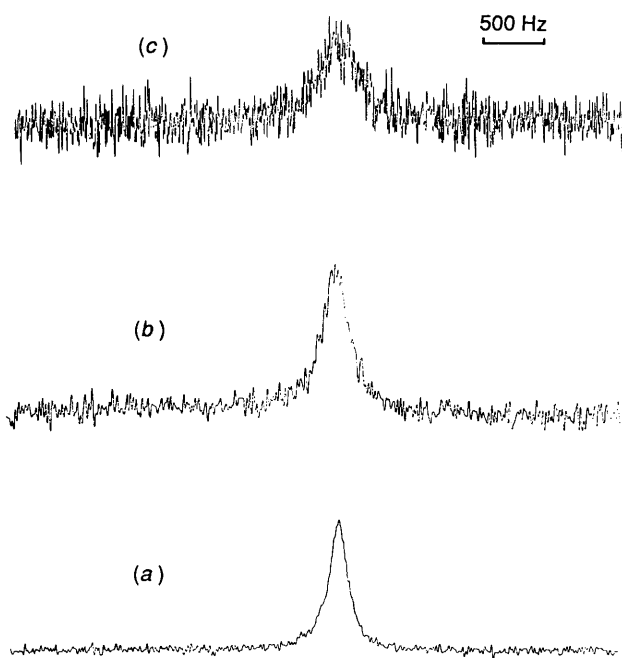

Figure 2. Nitrogen-14 n.m.r. spectra of calcium(II)-glycine solutions (pD 10): (a) 1 mol dm⁻³ glycine, (b) 0.5 mol dm⁻³ CaCl₂ + 1 mol dm⁻³ glycine, and (c) 1 mol dm⁻³ CaCl₂ + 1 mol dm⁻³ glycine

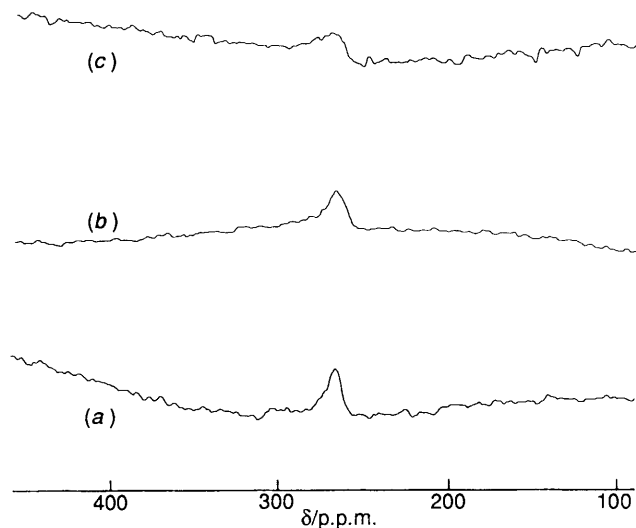

Figure 3. Oxygen-17 n.m.r. spectra of calcium(II)-glycine solutions (pH 10). Concentrations as in Figure 2

solution || reference, where reference denotes the reference half-cell || 0.15 mol dm⁻³ NaCl || 0.15 mol dm⁻³ NaCl saturated with AgCl | Ag-AgCl. The e.m.f.s for the c.i.s.e. (E_{Ca}) and the g.e. (E_G) are represented at 37 °C by equations (1) and (2), respectively, where the E^0 parameters are constants,

$$E_{Ca} = E_{Ca}^0 + 30.77 \log [Ca^{2+}] + E_j \quad (1)$$

$$E_G = E_G^0 + 61.55 \log [H^+] + E_j \quad (2)$$

and E_j , the liquid-junction potential arising between the equilibrium solution and the salt bridge, was found to be approximated by $-300[H^+]$ mV. The experimental procedures were analogous to those employed in a lead(II)-iminodiacetic acid system reported previously, for which lead-ion selective and glass electrodes were used.¹²

Table 1. Protonation constants (K_n) for glycine, DL-alanine, β -alanine, and DL-aspartic acid in 0.15 mol dm⁻³ NaCl at 37 °C: $K_n = [H_nL^{(n-s)+}]/[H^+][H_{n-1}L^{(n-s-1)+}]$, where $s = 1$ for amino acids other than DL-aspartic acid, for which $s = 2$. The numbers in parentheses are standard deviations of the last decimal place

Amino acid	$\log K_1$	$\log K_2$	$\log K_3$
Glycine	9.210(2)	2.314(3)	—
DL-Alanine	9.311(4)	2.297(5)	—
β -Alanine	9.706(2)	3.495(3)	—
DL-Aspartic acid	9.354(5)	3.575(5)	1.943(5)

N.M.R. Spectral Measurements.—The ¹⁴N spectra in D₂O were obtained at 28 °C by means of a JEOL JNM-FX100 spectrometer operating in the Fourier-transform mode at a frequency of 7.15 MHz. The spectra were measured by using a sample tube of outside diameter 10 mm and 8 k data were collected over a spectral width of 5 kHz. The chemical shifts were obtained relative to SiMe₄ measured in a separate experiment. Natural-abundance ¹⁷O n.m.r. spectra were recorded at 30 °C on a Varian XL-200 spectrometer operated at 27.12 MHz in the Fourier-transform mode, using a tube of outside diameter 10 mm and a 90° pulse. The spectral width was 20 kHz with 7 k data points. The chemical shifts were referred to H₂¹⁷O as internal standard.

Evaluation of Formation Constants of Calcium(II)-Amino Acid Complexes and Assignment of their N.M.R. Spectra.—Protonation constants of amino acids and formation constants of complexes. The protonation constants $K_n (= [H_nL^{(n-s)+}]/[H^+][H_{n-1}L^{(n-s-1)+}]$; where $s = 1$ for amino acids other than DL-aspartic acid, for which $s = 2$) for the amino acids were determined by the usual curve-fitting method.¹²

The composition of the complexes and their approximate formation constants were determined as follows. Under the condition of c_L (total concentration of ligand) > c_{Ca} (total concentration of Ca^{II}) and on the assumption of the formation of a single complex, the combination of the mass-balance equations for calcium and ligand yields equation (3), where κ_{pqr}

$$\log \Phi = \log \{ (c_{Ca} - [Ca^{2+}]) (1 + 1/K_1[H^+]) / [Ca^{2+}] c_L \} \\ = \log p\kappa_{pqr} + (p-1) \log [Ca^{2+}] + (q-r) \log [H^+] \\ + (1-r) \log (1 + 1/K_1[H^+]) + (r-1) \log c_L \quad (3)$$

denotes the formation constant of $[Ca_pH_qL_r]^{(2p+q-sr)+}$ from Ca^{2+} and $HL^{(1-s)+}$. Since the term on the left is experimentally accessible, $\log \Phi$ can be plotted against $-\log [H^+]$. The plots for the glycine, DL-alanine, and β -alanine systems yielded straight lines of unit slope practically independent of c_{Ca} and c_L in the range $-\log [H^+] > 9$. This indicates that the species formed has the composition $p = 1$, $q = 0$, and $r = 1$, i.e. $[CaL]^+$ in the three systems. Their approximate formation constants κ_{101} could be determined from the intercepts of the plots. In these systems no reasonable plot could be drawn in the range $-\log [H^+] < 9$, probably due to the low extent of the complex formation. In the DL-aspartic acid system the data points in the $-\log [H^+]$ region from 6 to 8 followed a horizontal line. This indicates that $p = q = r = 1$, i.e. the species formed in this range is $[Ca(HL)]^+$. In the range of $-\log [H^+] > 8$ the data were fitted to a straight line with slope = -1 independent of c_{Ca} and c_L , which certified the formation of a complex having $p = 1$, $q = 0$, and $r = 1$, namely $[CaL]$. The approximate formation constants of the two species were determined from the intercepts of the plots.

The protonation and formation constants thus estimated were finally refined with the least-squares computer program MIQUV,¹³ which computes the formation constants that

Table 2. Formation constants (κ_{pqr} and β_{pqr}) for glycine, DL-alanine, β -alanine, and DL-aspartic acid complexes of calcium(II) in 0.15 mol dm⁻³ NaCl at 37 °C: $\kappa_{pqr} = [\text{Ca}_p\text{H}_q\text{L}_r]^{(2p+q-sr)+}[\text{H}^+]^{r-q}/[\text{Ca}^{2+}]^p[\text{HL}^{(1-s)+}]^q$; $\beta_{pqr} = [\text{Ca}_p\text{H}_q\text{L}_r]^{(2p+q-sr)+}/[\text{Ca}^{2+}]^p[\text{H}^+]^q[\text{L}^{s-}]^r$, where $s = 1$ for amino acids other than DL-aspartic acid, for which $s = 2$. The numbers in parentheses are standard deviations of the last decimal place

Species proposed	pqr	Glycine		DL-Alanine	
		$\log \kappa_{pqr}$	$\log \beta_{pqr}$	$\log \kappa_{pqr}$	$\log \beta_{pqr}$
$[\text{Ca}(\text{HL})]^+$	111	—	—	—	—
$[\text{CaL}]^{(2-s)+}$	101	-7.744(10)	1.465(10)	-8.002(13)	1.309(13)
		β -Alanine		DL-Aspartic acid	
		$\log \kappa_{pqr}$	$\log \beta_{pqr}$	$\log \kappa_{pqr}$	$\log \beta_{pqr}$
$[\text{Ca}(\text{HL})]^+$	111	—	—	1.213(15)	10.567(15)
$[\text{CaL}]^{(2-s)+}$	101	-8.067(9)	1.639(9)	-7.365(5)	1.989(5)

minimise the sum $U = \sum_i w_i (E_i^{\text{obs.}} - E_i^{\text{calc.}})^2$ including all the e.m.f. readings for both electrodes and where w_i is a weighting factor $1/\sigma_i^2$, σ_i^2 being the estimated variance associated with the i th observation.

The possibility of other species $[\text{Ca}(\text{HL})]^{2+}$ and $[\text{CaL}_2]$ in the glycine, DL-alanine, and β -alanine systems, which were not found by the graphical procedures, was tested, but they were rejected. In the DL-aspartic acid system the formation of species such as $[\text{Ca}(\text{HL})\text{L}]^-$, $[\text{Ca}(\text{HL})_2]$, and $[\text{CaL}_2]^{2-}$ was examined, but no improvement in the fit of the experimental data was obtained by inclusion of these species.

The final results for the four systems are collected in Tables 1 and 2.

N.m.r. spectra. The ¹⁴N and ¹⁷O n.m.r. spectra of the calcium(II)-glycine system are shown in Figures 2 and 3, respectively.

Addition of CaCl₂, which leads to the co-existence of $[\text{CaL}]^+$ and $\text{L}^- (= \text{H}_2\text{NCH}_2\text{CO}_2^-)$ at pD 10, seems to cause no further ¹⁴N chemical shift relative to that for glycine only, but to result in further broadening of the ¹⁴N peaks, with increasing CaCl₂ concentration. Glycine at pH 10, where it is present in the form of L^- , shows a downfield shift of about 270 p.p.m. in the ¹⁷O n.m.r. spectra relative to H₂¹⁷O. As is the case in the ¹⁴N n.m.r. spectra, calcium chloride seems to induce no clear ¹⁷O chemical shift relative to glycine alone, but only to cause the peak broadening with increasing concentration of the salt. Analogous results were obtained for the DL-alanine and β -alanine systems. N.m.r. spectra could not be obtained for the complexes in the DL-aspartic acid system due to the low solubility of that acid.

Results and Discussion

Only the $[\text{CaL}]^+$ species were found in the glycine, DL-alanine, and β -alanine systems. In the glycine and DL-alanine systems this is consistent with the results at 25 °C and infinite dilution proposed by Davies and Waing,¹⁴ who reported the formation constant for the glycine system to be 1.43 and that for the DL-alanine system to be 1.24 in log β units. No result for the β -alanine system seems to have been reported. The two complexes $[\text{Ca}(\text{HL})]^+$ and $[\text{CaL}]$ were found in the DL-aspartic acid system. Lumb and Martell¹⁵ found the $[\text{CaL}]$ species in this system at 25 °C in 0.1 mol dm⁻³ KCl, the formation constant being 1.60 in log β units, with no indication of the formation of the protonated species $[\text{Ca}(\text{HL})]^+$. The protonation constants reported by them were $\log K_1 = 9.62$, $\log K_2 = 3.70$, and $\log K_3 = 1.94$.

The occurrence of peak broadening in both the ¹⁴N and ¹⁷O n.m.r. spectra on addition of CaCl₂ may be taken as evidence that the amino and carboxylate groups have weak interactions

with Ca^{II} within the $[\text{CaL}]^+$ species. The interactions may be too weak to bring about any distinguishable chemical shift. In conclusion, it may be said that Ca^{II} forms chelates with glycine, DL-alanine, and β -alanine within the $[\text{CaL}]^+$ complexes.

Raman and i.r. spectra were also measured for aqueous solutions containing Ca^{II} and each amino acid, but no evidence for the co-ordination of Ca^{II} to the amino acids was obtained. This observation may be ascribed to prevailing electrostatic interactions between Ca^{II} and the CO₂⁻ and NH₂ groups.

Acknowledgements

We thank Professor H. Tomiyasu and Dr. M. Harada of the Tokyo Institute of Technology for their help in the measurement of the ¹⁴N n.m.r. spectra.

References

- L. G. Sillén and A. E. Martell, 'Stability Constants of Metal-Ion Complexes,' Special Publ., The Chemical Society, London, 1964, no. 17.
- L. G. Sillén and A. E. Martell, 'Stability Constants of Metal-Ion Complexes,' Special Publ., The Chemical Society, London, 1971, no. 25.
- D. D. Perrin, 'Stability Constants of Metal-Ion Complexes,' IUPAC Chemical Data Series no. 22, Pergamon, New York, Toronto, Sydney, Paris, Frankfurt, 1979, part B.
- D. D. Perrin and R. P. Agarwal, in 'Metal Ions in Biological Systems,' vol. 2, ed. H. Sigel, Marcel Dekker, New York, 1973, ch. 4.
- H. Einspahr and C. E. Bugg, in 'Metal Ions in Biological Systems,' vol. 17, ed. H. Sigel, Marcel Dekker, New York, Basle, 1984, ch. 2.
- R. B. Martin, in 'Metal Ions in Biological Systems,' vol. 17, ed. H. Sigel, Marcel Dekker, New York, Basle, 1984, ch. 1.
- D. D. Perrin, W. L. F. Armarego, and D. R. Perrin, 'Purification of Laboratory Chemicals,' Pergamon, Oxford, New York, Toronto, Sydney, Paris, Frankfurt, 1980.
- M. Maeda, *J. Phys. Chem.*, 1986, **90**, 1134.
- M. Maeda, Y. Murata, and K. Ito, *J. Chem. Soc., Dalton Trans.*, 1987, 1853.
- A. S. Brown, *J. Am. Chem. Soc.*, 1934, **56**, 646.
- I. Hansson, S. Ahrland, R. G. Bates, G. Biedermann, D. Dyrssen, E. Högfeldt, A. E. Martell, J. J. Morgan, P. W. Schindler, T. B. Warner, and M. Whitfield, in 'Nature of Seawater,' ed. E. D. Goldberg, Dahlem Konferenzen, Berlin, 1975, p. 263.
- M. Maeda, M. Ohnishi, and G. Nakagawa, *J. Inorg. Nucl. Chem.*, 1981, **43**, 107.
- A. Vacca and A. Sabatini, in 'Computational Methods for the Determination of Formation Constants,' ed. D. J. Leggett, Plenum, New York, London, 1985, ch. 5.
- C. W. Davies and G. H. Waing, *J. Chem. Soc.*, 1950, 301.
- R. F. Lumb and A. E. Martell, *J. Phys. Chem.*, 1953, **57**, 690.